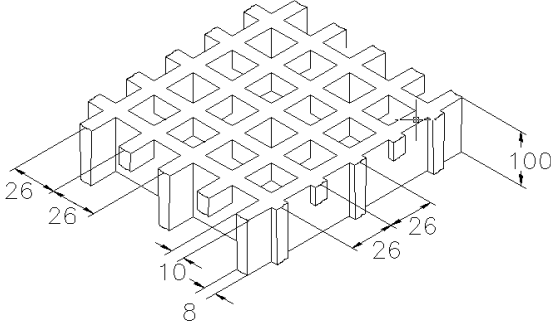

SCH 52/100_CFR

06.05.2011 - Rev. 4

MOLDED GRATINGS

Mesh	mm 52 x 52 main	
	mm 26 x 26 secondary	
Clear span	mm 19 x 19	
Height	mm 100	
Bearing bar thickness	mm 10 upper part	
	mm 8 bottom part	
Color	Black	

Raw materials	Polyester Resin	
	Roving glass fiber type "E"	
	Inorganic fillers without halogens + Carbon black conductive powder	

Resin type	Modulus of elasticity	Ultimate stress
CFR	15000 MPa	325 MPa

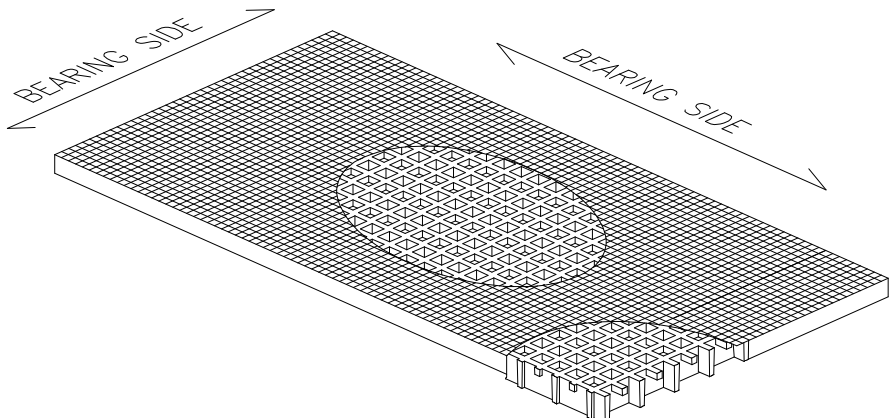
Standard panels		
mm 1005 x 1510		
Weight kg/m² 56		
tolerance		± mm 5 panel dimensions
		± mm 2 height

Surface	M	Meniscus	Antiskid level R13 V10 norm DIN 51130
----------------	---	-----------------	--

Reaction to fire	Fire retardant	Spread ≤ 25 norm ASTM E84-98
		ASTM D635 Elapsed time and burned length < 25 mm

Surface and Volume electrical resistivity. Dielectric strength	Excellent Conductivity	EN 61340-2.3 Par. 8.1 and 8.2 – IEC 61340-4.1 Par. 5.1.2 ref. ISO 1957 – IEC 61340-4.5 - ASTM D149-97a
---	-------------------------------	---

LOADS

MAXIMUM SUGGESTED LOADS

Type of support	On the line of the two ends of the panel
Limits determined by	Deflection (load sagging)
the maximum deflection admitted , is 1/200 of the distance between the supports	
According to the standard DIN 24537-3 deviation due to the load may be no more than 1/200 of the land width and the difference in height between neighbouring joints between loaded and unloaded floor coverings may be no more than 4 mm.	

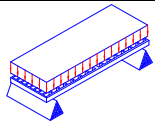
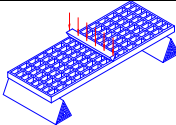
DISTIBUTED LOAD			CONCENTRATED LOAD			
	Distance between supports [cm]	Load with deflection equal to 1/200 [kg/m ²]		Load with deflection equal to 1/100	Distance between supports [cm]	Load with deflection equal to 1/200 [cm]
	80	18700	37400	80	9350	18700
	100	9550	19150	100	5950	11950
	120	5500	11050	120	4150	8300
	140	3450	6950	140	3050	6100

All lighter loads are admitted

Limits determined by	Admitted stresses (stress determined by the load)
the maximum admitted stress is 1/5 of the ultimate stress (safety factor is equal to 0.20 – the ultimate stress is 5 times the specified load)	

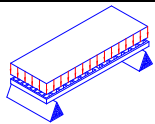
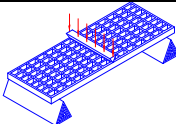
DISTIBUTED LOAD			CONCENTRATED LOAD		
	Distance between supports [cm]	Maximum admitted load [kg/m ²]		Distance between supports [cm]	Maximum admitted load [kg/m]
	80	24750	80	9900	
	100	15800	100	7900	
	120	11000	120	6600	
	140	8050	140	5650	

All lighter loads are admitted

- The above characteristics are meant as reference values for standard material in ambient working temperature. Even if they are not to be considered as guaranteed characteristics they are based on our experience and are supplied in good faith.
- According to the standard DIN 24537-3 the conversion safety factor should be 0.75 for internal environmental exposure conditions, 0.65 for external exposure conditions, and 0.50 for aggressive exposure conditions.
- No matter which are the exposure conditions, chemical resistance must be always verified by contacting M.M.technical department.
- In case of heavy duty load compressive strength must be verified.