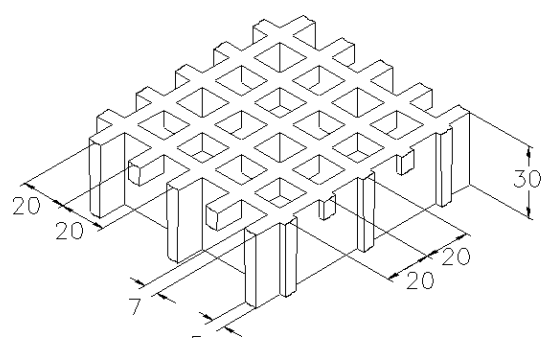

SCH 13/30_IFR

06.05.2011 - Rev. 4

MOLDED GRATINGS

Mesh	mm 40 x 40 main	
	mm 20 x 20 secondary	
Clear span	mm 13 x 13	
Height	mm 30	
Bearing bar thickness	mm 7 upper part	
	mm 5 bottom part	
Color	Grey RAL 7004 <i>indicative RAL reference</i>	

Raw materials	Polyester Resin
	Roving glass fiber type "E"
	Inorganic fillers without halogens

Resin type	Modulus of elasticity	Ultimate stress
IFR	15000 MPa	325 MPa

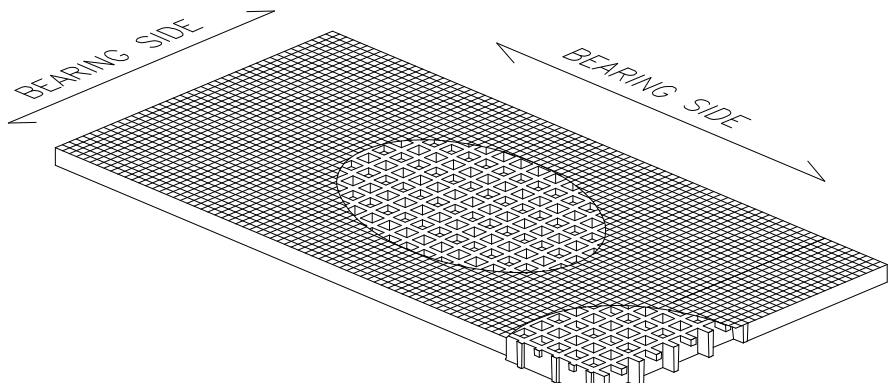
Standard panels	
mm 1007 x 3007	
Weight kg/m² 19	
tolerance	± mm 5 panel dimensions ± mm 2 height

Surface	S	Smooth	Antiskid level R10 V10 norm DIN 51130
	M	Meniscus	Antiskid level R13 V10 norm DIN 51130
	A	Quartz	Antiskid level R13 V10 norm DIN 51130

Reaction to fire	Fire retardant	Spread ≤ 25 norm ASTM E84-98
		Level B₁-S1 norm EN 13501-1

Ageing resistance	Ageing test made with UV lamp according to ASTM G154-06 and passed with 5 points on the gray range and without evident defects (test made with 1500 hours of exposure to 4 hours alternate cycles at a UV temperature of 60°C and 4 hours at a condensed temperature of 50°C irradiated by UVB 313 nm lamp, radiance 0,71 W/m ²)
	After the exposure to heat, cold and humidity cycles according to UNI EN ISO 9142/04 norm (n° 21 cycles type D3) there is no evidence of defects

LOADS

MAXIMUM SUGGESTED LOADS

Type of support	On the line of the two ends of the panel
Limits determined by	Deflection (load sagging)
the maximum deflection admitted , is 1/200 of the distance between the supports	
According to the standard DIN 24537-3 deviation due to the load may be no more than 1/200 of the land width and the difference in height between neighbouring joints between loaded and unloaded floor coverings may be no more than 4 mm.	

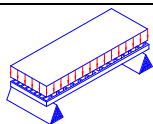
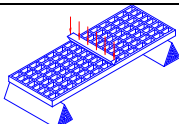
DISTIBUTED LOAD			CONCENTRATED LOAD			
	Distance between supports [cm]	Load with deflection equal to 1/200 [kg/m ²]		Load with deflection equal to 1/100	Distance between supports [cm]	Load with deflection equal to 1/200 [cm]
	50	2250	4500	50	700	1400
	70	800	1650	70	350	700
	90	350	750	90	200	400
	110	200	400	110	100	250

All lighter loads are admitted

Limits determined by	Admitted stresses (stress determined by the load)
the maximum admitted stress is 1/5 of the ultimate stress (safety factor is equal to 0.20 – the ultimate stress is 5 times the specified load)	

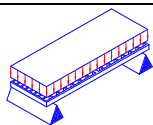
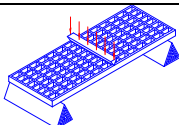
DISTIBUTED LOAD			CONCENTRATED LOAD		
	Distance between supports [cm]	Maximum admitted load [kg/m ²]		Distance between supports [cm]	Maximum admitted load [kg/m]
	50	5250	50	1300	
	70	2650	70	900	
	90	1600	90	700	
	110	1050	110	550	

All lighter loads are admitted

- The above characteristics are meant as reference values for standard material in ambient working temperature. Even if they are not to be considered as guaranteed characteristics they are based on our experience and are supplied in good faith.
- According to the standard DIN 24537-3 the conversion safety factor should be 0.75 for internal environmental exposure conditions, 0.65 for external exposure conditions, and 0.50 for aggressive exposure conditions.
- No matter which are the exposure conditions, chemical resistance must be always verified by contacting M.M. technical department.
- In case of heavy duty load compressive strength must be verified.