

PROFILE

53P00400050 ISO CE-D

TYPE: PROFILE "P FLAT" GROUP: CE-D MARKING: Marked CE

RESIN: isophthalic resin ISO
REINFORCEMENT: Roving glass fiber type "E" - Continuous strand mat
- Polyester surface veil
PRODUCTION TECHNOLOGY: pultrusion
NORM: EN 13706 -2



Indicative image

PHYSICAL PROPERTIES

LONGITUDINAL THERMAL EXPANSION COEFFICIENT (α)	10,8x10 ⁻⁶	K ⁻¹	ISO 11359-2
TRANSVERSE THERMAL EXPANSION COEFFICIENT (α)	27,7x10 ⁻⁶	K ⁻¹	ISO 11359-2
FIBERGLASS WEIGHT RATIO	68	%	EN ISO 1172
CURING DEGREE (c)	100	%	EN ISO 11357-5

DIMENSIONS

HEIGHT (A)	40	mm
WIDTH (B)	5	mm
RADIUS (R1)	> 1	mm
RADIUS (R2)	> 1	mm

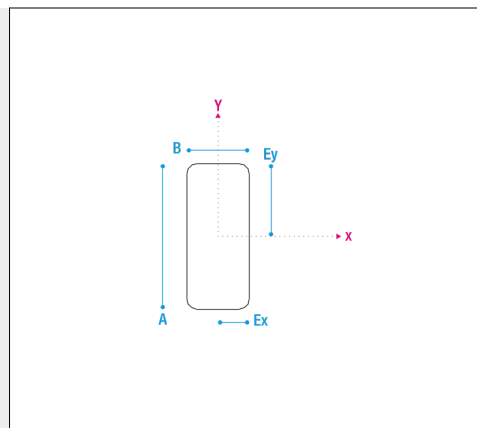

Dimensional tolerances according to EN 13706 -2 annex b

WEIGHT: 0,370 Kg/m

GEOMETRY

MOMENT OF INERZIA (Jx)	25919	mm ⁴	MOMENT OF INERZIA (Jy)	407	mm ⁴
SECTION MODULUS (Wx)	1296	mm ³	SECTION MODULUS (Wy)	163	mm ³
CENTROID IN X DIRECTION (Ex)	2,5	mm	CENTROID IN Y DIRECTION (Ey)	20	mm

REACTION TO FIRE

CLASS E | NORM EN 13501-1

STANDARD DIMENSIONS AND COLOURS

6000 mm - GRAY RAL 7035



M.M. SRL a socio unico
soggetta ad attività di direzione
e coordinamento di 4M. srl

Via Antonio Zanussi 300/302
33100 Udine (Italy)
Cap. Soc. EURO 100.000 i.v.

P.Iva / C.F. 02984500302
Reg. Imp. PN-UD 02984500302
PEC mm-grigliati@pec-neispa.com

tel. +39.0432.522970
fax +39.0432.52253
info@mmgrigliati.it

**COMPANY WITH
QUALITY SYSTEM
CERTIFIED BY DNV GL**
= ISO 9001 =

PROFILE

53P00400050 ISO CE-D

MECHANICAL PROPERTIES

BENDING EFFECTIVE ELASTIC MODULUS

	MEAN VALUE	CHARACTERISTIC VALUE	NORM
BENDING EFFECTIVE ELASTIC MODULUS, FULL SECTION (E_{eff})	28,84 GPa		ANNEX D EN 13706-2

FLEXURAL PROPERTIES

	MEAN VALUE	CHARACTERISTIC VALUE	NORM
LONGITUDINAL BENDING STRENGTH (f_{fl})	369,1 MPa	265,6 MPa	EN ISO 14125
TRANSVERSAL BENDING STRENGTH (f_{ft})	228 MPa	201,8 MPa	EN ISO 14125
LONGITUDINAL BENDING ELASTIC MODULUS (E_{fl})	19,42 GPa		EN ISO 14125 (CLASS 4)
TRANSVERSE BENDING ELASTIC MODULUS (E_{ft})	15,26 GPa		EN ISO 14125 (CLASS 4)

TENSILE PROPERTIES

	MEAN VALUE	CHARACTERISTIC VALUE	NORM
LONGITUDINAL TENSILE STRENGTH (f_{tl})	471,1 MPa	392,7 MPa	EN ISO 527-4
TRANSVERSAL TENSILE STRENGTH (f_{tt})	92,5 MPa	86,9 MPa	EN ISO 527-4
LONGITUDINAL TENSILE ELASTIC MODULUS (E_{tl})	30,54 GPa		EN ISO 527-4
TRANSVERSAL TENSILE ELASTIC MODULUS (E_{tt})	10,65 GPa		EN ISO 527-4
LONGITUDINAL POISSON RATIO (ν_{LT})	0,35		EN ISO 527-4
TRANSVERSAL POISSON RATIO (ν_{TL})	0,08		EN ISO 527-4

COMPRESSION PROPERTIES

	MEAN VALUE	CHARACTERISTIC VALUE	NORM
LONGITUDINAL COMPRESSIVE STRENGTH (f_{cl})	386,9 MPa	305,2 MPa	EN ISO 14126
TRANSVERSAL COMPRESSIVE STRENGTH (f_{ct})	140,5 MPa	109,9 MPa	EN ISO 14126
LONGITUDINAL COMPRESSIVE ELASTIC MODULUS (E_{cl})	28,8 GPa		EN ISO 14126
TRANSVERSAL COMPRESSIVE ELASTIC MODULUS (E_{ct})	10,4 GPa		EN ISO 14126

INTERLAMINAR AND IN-PLANE SHEAR PROPERTIES

	MEAN VALUE	CHARACTERISTIC VALUE	NORM
LONGITUDINAL INTERLAMINAR SHEAR STRENGTH (f_{vl})	22,54 MPa	20,46 MPa	EN ISO 14130
INTERLAMINAR SHEAR MODULUS (G_{LT})	3,63 GPa		EN ISO 15310

PIN BEARING STRENGTH

	MEAN VALUE	CHARACTERISTIC VALUE	NORM
LONGITUDINAL PIN BEARING STRENGTH (f_{pL})	161,78 MPa	131,2 MPa	ANNEX E EN 13706-2
TRANSVERSAL PIN BEARING STRENGTH (f_{pT})	156,56 MPa	139,54 MPa	ANNEX E EN 13706-2

The product can be used in humidity range 0-100% and temperature range -30 °C / + 50 °C, in case of different environmental conditions or contact with aggressive chemicals (acids and alkalis), please contact M.M. Technical Department.

The estimated service life is 50 years, on condition that packing, transport, storage, use and installation, maintenance and repairing are carried out properly. Indications about service life must not be intended as product warranty provided by the manufacturer, but shall be considered as guidelines to help the selection of the correct products in relationship with the

service life foreseen for the main works, under reasonable economical criteria.

ATTENTION: The average values reported in the table shall not be considered as minimum values for material acceptance. For strength verifications the Characteristic Values as defined and required by the Standards in force shall be considered. It is highly recommended to pay extra care to the local and global stability checks of profiles. Please refer to "Design Guidelines". For clarifications please contact M.M. Technical Department.

DESIGN GUIDELINES

1. For a correct design of FRP structures, we recommend to pay particular attention to the local and global buckling of the profiles. Contact M.M.'s technical department for further assistance.
2. Avoid to apply tensile/compressive concentrated loads on the flanges of the profiles as illustrated in the below drawings.

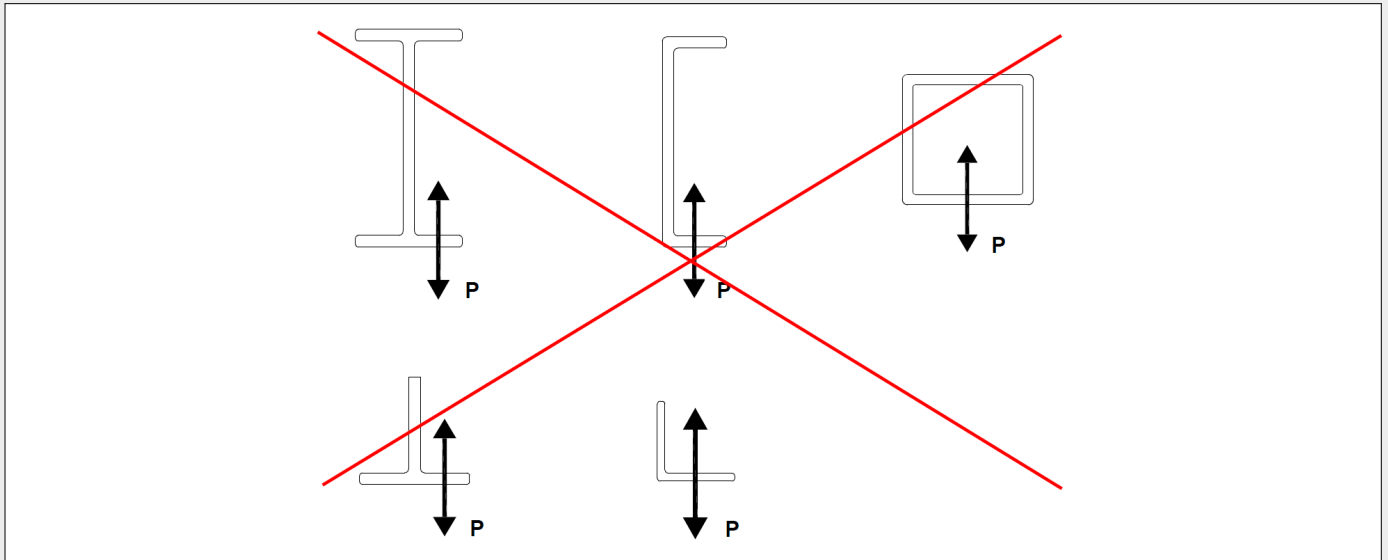

3. It is highly recommended to pay extra care to the local and global stability checks of profiles. Please refer to addendum "Design Guideline".

